

INFINITI VC-TURBO ENGINE

COMPARISON OF VC-TURBO TECHNOLOGY IN HIGH AND LOW COMPRESSION RATIOS

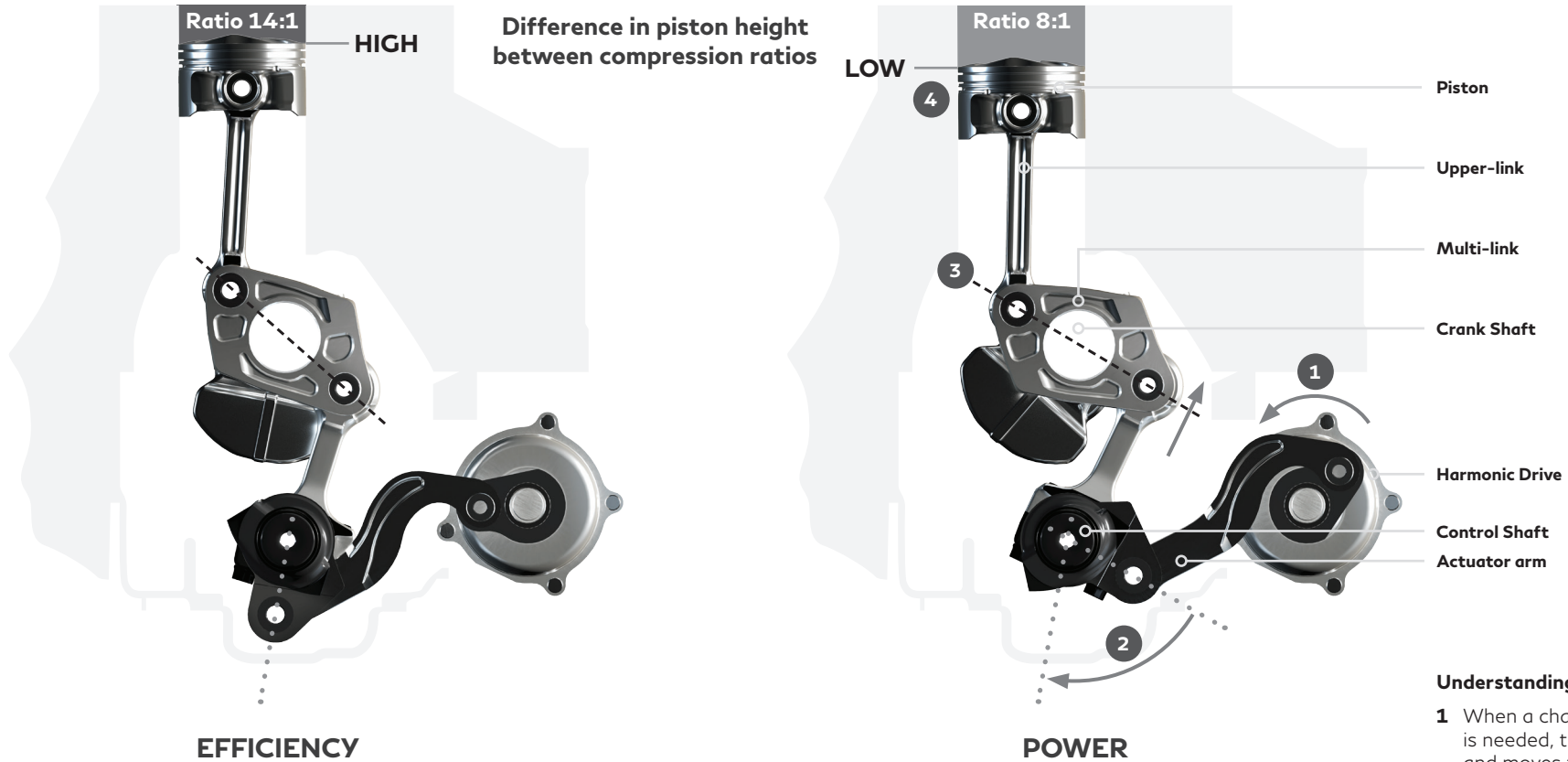

Understanding VC-Turbo technology

- 1 When a change in compression ratio is needed, the Harmonic Drive turns and moves the actuator arm
- 2 The actuator arm rotates the control shaft
- 3 As the control shaft rotates, it acts upon the lower-link, which changes the angle of the multi-link
- 4 The multi-link adjusts the height the piston can reach within the cylinder, thus changing the compression ratio



INFINITI

EMPOWER THE DRIVE